

# DW60

## Wheel Dumpers



**WACKER  
NEUSON**  
*all it takes!*



### The efficient load carrier

The DW60, with its 6,000 kg payload, represents one of the larger wheel dumpers by Wacker Neuson. The environmentally conscious, modern Stage V turbo diesel engine protects the environment without having to sacrifice productivity. Constant tractive force, hydrostatic brake effect and the comprehensively equipped optional cabin ensure fatigue-free work with the same concentration. Even with all the comfort, no sacrifice is necessary in terms of safety or performance. Additional safety options and a broad range of equipment options complete the machine.

- Minimum consumption, optimum power use, easy to operate: the hydrostatic 4-wheel drive with automatic ECO mode and automatic brake light
- Standard auto-stop function, which automatically switches off the machine after a set time
- Completely maintenance-free spring-loaded parking brake is automatically activated when the engine is stopped
- Fully equipped cabin with comfort features and optional skip guard
- The entry in signal color increases safety and gives the steps and handle better visibility.

## DW60 Technical specifications

	Front tip skip	Swivel tip skip
<b>Operating data</b>		
Payload kg	6,000	6,000
Shipping weight ROPS kg	3,874	4,118
Shipping weight cabin kg	4,073	4,313
Operating weight ROPS kg	3,875	4,115
Operating weight cabin kg	4,217	4,457
Skip capacity struck l	2,700	2,350
Skip capacity heaped l	3,600	3,150
Skip capacity water volume l	1,600	1,600
<b>Engine / Motor</b>		
Engine / Motor manufacturer basic machine	DEUTZ	DEUTZ
Engine / Motor type	TD 2.2	TD 2.2
Engine / Motor	Water-cooled 3-cylinder turbo diesel engine	Water-cooled 3-cylinder turbo diesel engine
Engine performance according to ISO 3046/1 kW	44.5	44.5
Emission standards stage	5	5
Displacement cm <sup>3</sup>	2,194	2,194
Engine / Motor manufacturer optional engine	DEUTZ	DEUTZ
Engine / Motor type	TD 2.9	TD 2.9
Engine performance kW	55.4	55.4
Emission standards stage	5	5
Travel speed max. km/h	25	25
Articulation angle °	29	29
Pendulum angle °	11.5	11.5
Turning radius mm	5,125	5,125
Gradeability %	60	60
Tires	Mitas MPT-01	Mitas MPT-01
L x W x H mm	4,496 x 2,328 x 3,208	4,747 x 2,230 x 3,208
Steering pump	Axial piston pump	Axial piston pump
Flow rate l/min	123.2	123.2
Operating pressure bar	214	214
Duty pump	Gear pump	Gear pump
Flow rate l/min	59	59
Operating pressure bar	240	240
Sound level (LwA) dB(A)	101	101
<b>Battery</b>		
Battery Ah	100	100
Battery V	14	14

## DW60 Dimensions

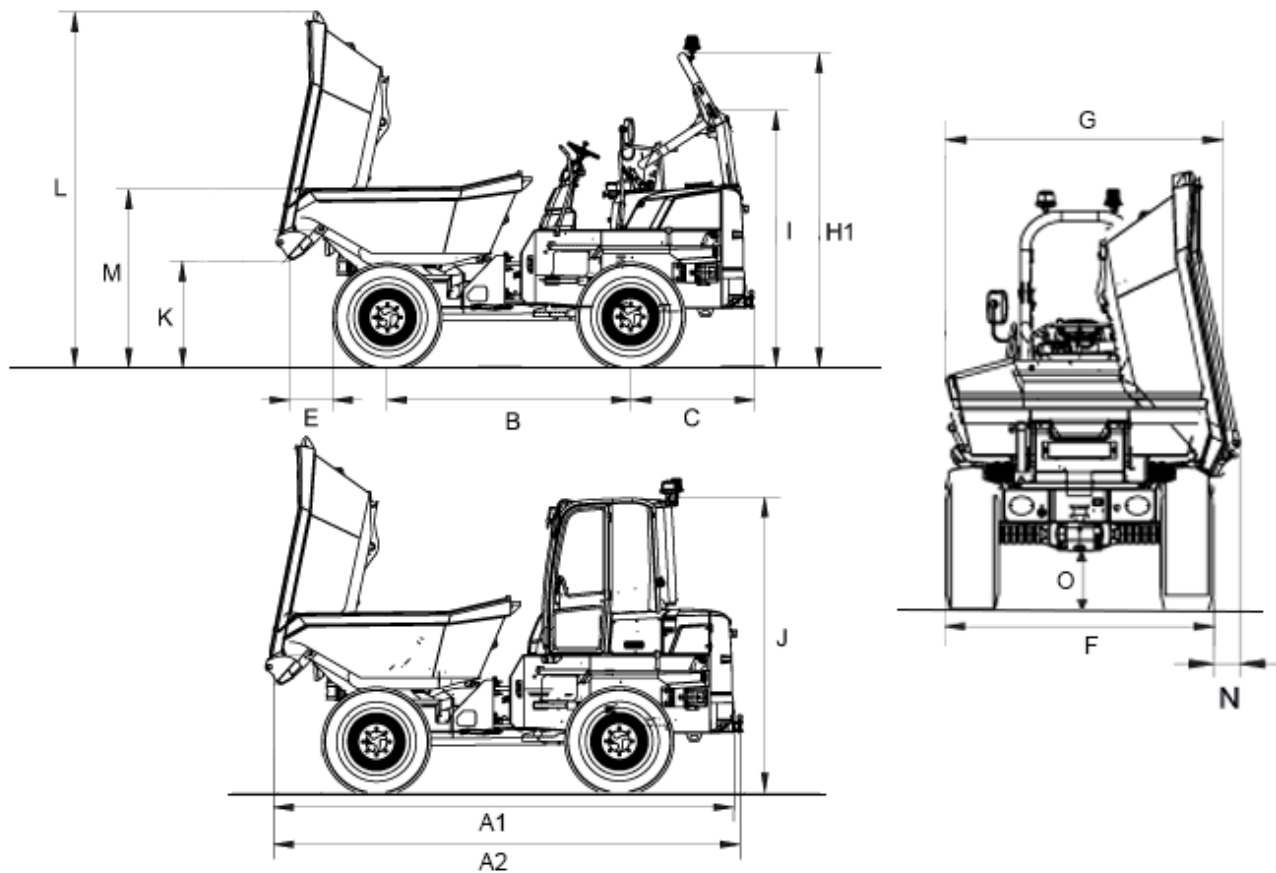

		Front tip skip	Swivel tip skip	Special skip
A	Overall length	4,554 mm	4,806 mm	4,744 mm
B	Wheelbase	2,485 mm	2,485 mm	2,485 mm
C	Rear overhang	1,263 mm	1,263 mm	1,263 mm
E	Dumping distance	565 mm	456 mm	446 mm
F	Width	2,230 mm	2,230 mm	2,230 mm
G	Skip width	2,328 mm	2,217 mm	2,218 mm
H	Height ROPS	3,240 mm	3,240 mm	3,240 mm
I	Height ROPS tilted	2,591 mm	2,591 mm	2,591 mm
J	Height Cabine	3,044 mm	3,044 mm	3,044 mm
K	Dump height max.	384 mm	1,101 mm	1,153 mm
L	Skip height tilted	2,417 mm	3,639 mm	3,639 mm
M	Skip height	1,828 mm	1,837 mm	1,830 mm
N	Dumping distance		227.5 mm	228 mm
O	Ground clearance	369 mm	369 mm	369 mm
--	Dump angle	50 °	48 °	48 °

Please note: that product availability can vary from country to country. It is possible that information / products may not be available in your country. More detailed information on engine power can be found in the operator's manual; the stated power may vary due to specific operating conditions. Subject to alterations and errors excepted. Applicable also to illustrations.

Copyright © 2022 Wacker Neuson SE.