

Dimensions

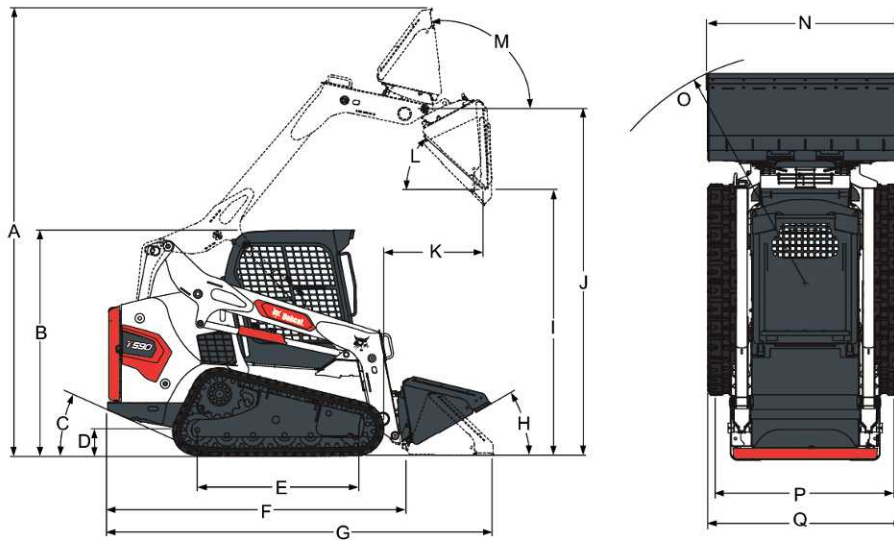

(A) Operating height	3901.0 mm
(B) Height with operator cab	1972.0 mm
(C) Angle of departure	27.8°
(D) Ground clearance	188.0 mm
(E) Ground contact length	1402.0 mm
(F) Length without attachment	2657.0 mm
(G) Length with standard bucket	3378.0 mm
(H) Rollback at ground position	30.0°
(I) Dump height with standard bucket	2319.0 mm
(J) Height to bucket hinge pin	3023.0 mm
(K) Dump reach at maximum height	887.0 mm
(L) Dump angle at maximum height	42.0°
(M) Rollback fully raised at maximum height	97.0°
(N) Bucket width, 68-inch	1727.0 mm
(N*) Bucket width, 74-inch	1880.0 mm
(O) Turning radius with standard bucket	2032.0 mm
(Q) Width over tracks, 320 mm tracks	1702.0 mm
(Q*) Width over tracks, 400 mm tracks	1782.0 mm

Machine Rating

Lift breakout force	2269 daN
Tilt breakout force	2179 daN
Ground pressure	24.10 kPa
Rated operating capacity (ISO 14397-1)	971 kg
Push force	3573 daN
Tipping load (ISO 14397-1)	2773 kg

Cycle Times

Raise lift arms	4.0 s
Lower lift arms	2.8 s
Bucket rollback	1.7 s
Bucket dump	2.5 s

Weights

Operating weight	3664 kg
Shipping weight	3283 kg
Ground pressure	40.00 kPa

Engine

Make / Model	Bobcat 2.4L, 97/68 EC
Compliance	Stage V
Fuel	Diesel
Cooling	Liquid
Power at 2600 RPM (ISO 14396)	50.7 kW
Torque at 1800 RPM (ISO 14396)	252.3 Nm
Number of cylinders	4
Displacement	2392 cm ³
Bore	90.0 mm
Stroke	94.0 mm
Lubrication	Gear pump pressure
Crankcase ventilation	Closed breathing
Air filter	Dry replaceable cartridge with safety element
Ignition	Diesel-compression
Starting aid	Glow plugs

Electrical

Alternator	90 A — open frame with internal regulator
Battery	12 V — 600 A cold cranking at -18°C — 115 min reserve capacity at 25 A
Starter	12 V GEAR TYPE 4.29 hp [3.2 kW]

Hydraulic System

Pump type	Engine driven, gear type
Pump capacity	64.70 L/min
Pump capacity (with high flow option)	101.10 L/min
System relief at quick couplers	23.8-24.5 MPa
Control valve	Three-spool, open-centre type with float detent on lift and electrically controlled auxiliary spool
Hydraulic filter	PREMIUM GRADE, ANTIWEAR MULTIVISCOSITY ISO V646, PETROLEUM BASED
Fluid lines	SAE standard tubelines, hoses, and fittings

Hydraulic Cylinders

Lift cylinder (2)	Double-acting
Lift cylinder bore	69.9 mm
Lift cylinder rod	41.4 mm
Lift cylinder stroke	540.0 mm
Tilt cylinder (2)	Double-acting
Tilt cylinder bore	69.9 mm
Tilt cylinder rod	38.1 mm
Tilt cylinder stroke	330.7 mm

Drive System

Transmission	Infinitely variable tandem hydrostatic piston pumps, driving two fully reversing hydrostatic motors
Tracks	320 mm width. Tension-grease cylinder and triple-flange spring rollers
Main drive	Fully hydrostatic, rubber track drive

Traction

Tracks	320 mm wide, rubber
Max. travel speed (low range – standard)	10.4 km/h
Max. travel speed (high range – optional)	16.0 km/h

Fluid Capacities

Cooling system with heater	10.90 L
Cooling system without heater	10.60 L
Engine oil with filter	9.20 L
Fuel tank	138.20 L
Hydraulic reservoir	7.57 L
Hydraulic / Hydrostatic system	36.00 L

Fluid Specifications

Engine coolant

Bobcat PG Coolant
 5 L can - 6904844A
 25 L container - 6904844B
 209 L drum - 6904844C
 1000 L tank - 6904844D

Engine oil

Oil must meet API Service Classification of CJ-4 or better, or ACEA E9 or better.
 Recommended SAE viscosity number for anticipated temperature range.

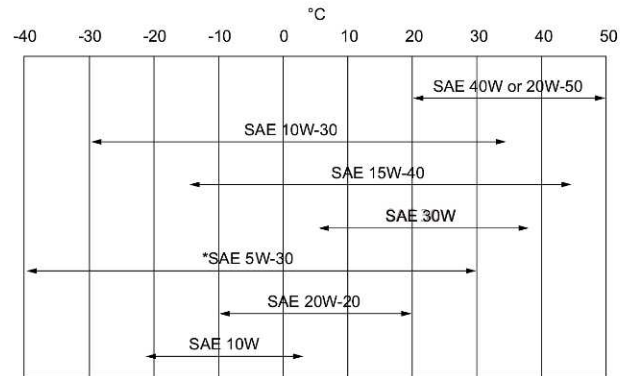

* Can be used only when available with appropriate diesel rating.

For synthetic oil use the recommendation from the oil manufacturer.

Hydraulic fluid

Bobcat Superior SH
 5 L can - 6904842A
 25 L container - 6904842B
 209 L drum - 6904842C
 1000 L tank - 6904842D
 Bobcat Bio Hydraulic
 5 L can - 6904843A
 25 L container - 6904843B
 209 L drum - 6904843C
 1000 L tank - 6904843D

Controls

Engine	Hand throttle or optional foot accelerator pedal (SJC)
Starting	Keyless start. Glow plugs automatically activated.
Front auxiliary (standard)	Proportional switch on Hand Levers or optional Selectable Joystick Controls (SJC)
Loader hydraulics tilt and lift	Foot Pedals or optional Selectable Joystick Controls (SJC)
Service brake	Two independent hydrostatic systems controlled by two hand-operated steering levers
Parking brake	Mechanical disc activated by manually operated switch on left instrument panel
Vehicle steering	Hand Levers or optional Selectable Joystick Controls (SJC)
Auxiliary pressure release	Pressure is relieved through the coupler block. Push in and hold for 5 s.
Rear auxiliary (optional)	Electrical switch on left-hand steering lever or joystick (SJC)

Instrumentation

The following loader functions are monitored by a combination of gauges and warning lights in the operator's line of sight. The system alerts the operator of monitored loader malfunctions by way of audible alarm and visual warning lights.

Standard Instrument Panel

- Gauges
 - Engine temperature
 - Fuel
- Indicators
 - Bobcat Interlock Control System
 - Engine preheat
 - Two speed
 - Turn signals
- Warning lights
 - Engine temperature
 - Fuel level
 - General warning
 - Seat belt
 - Seatbar down
 - Engine malfunction
 - Hydraulic system malfunction
 - Lift and tilt valve, hydraulics lock-out
 - Parking brake
 - Hydraulic oil temperature
 - Engine oil pressure
 - Hydraulic oil pressure
- Buttons
 - Work lights and road lights
 - High flow auxiliary hydraulics
 - Auxiliary hydraulics
 - Information (Hour meter, Engine RPM, Battery voltage, Service codes, Service reminder)
 - Traction lock override
 - Press to operate loader
- Rocker switch
 - Parking brake

- Alarm
 - Beep when error, warning or shutdown condition exists

Deluxe Instrument Panel

Same gauges, warning lights and other features as Standard Instrument Panel, plus:

- Gauges
 - Engine oil pressure / temperature
 - Hydrostatic charge pressure
 - Hydraulic oil temperature
 - Battery
- Additional features
 - Keyless start with password capability
 - Digital clock
 - User name and hourmeter
 - Attachments control information
 - Current job hours
 - High Flow lockouts
 - Multi-language display
 - Help screens
 - Auto Idle
 - DPF Management
 - Diagnostic capability
 - Engine/hydraulic systems shutdown function
 - Password lockout
- Icons
 - Active warnings
 - Vitals (Engine speed, Oil Pressure, Temperature, System voltage, Hydraulic charge pressure, Oil temperature)
 - Service
 - Main screen
 - Attachments
 - Security
 - DPF Regeneration
 - HEST Lamp
 - Inhibit DPF Regeneration
 - Forced Parked Regeneration
 - Display
- Buttons
 - Left scroll
 - Enter
 - Right scroll

Serviceability

Access is available to the following through the rear door/tailgate and rear screen:

- Air filter
- Alternator
- Battery
- Cooling system (engine oil and hydraulic oil coolers easily separable for cleaning)
- Engine oil and fuel filters
- Engine oil drain and dipstick
- Hydraulic oil fill and filter (access at the upper right side of the machine)
- Starter

Access available via the side of the machine:

Easy access to all lift arm grease points

Rod end of the tilt cylinder has a replaceable bushing
Tailgate has an optional lock for vandal-proofing
Tailgate is equipped with door-stop to hold door open while servicing
Tip-up operator cab gives access to certain hydraulic system components
Bob-Tach™ pivots have replaceable wear bushings

Standard Features

- Bobcat Interlock Control System (BICS)
- Parking brake
- Deluxe operator cab* Includes interior cab foam, side, top and rear windows, Deluxe wire harness, dome light and electrical power port ¹
- Noise reduction kit
- Operating lights, front and rear
- Deluxe instrument panel
- Keyless start with password capability
- Suspension seat
- Seat belt
- Seat bar
- Hydraulic bucket positioning (including ON/OFF switch)
- Tracks — rubber — 320 mm
- Spark Arrester
- Bob-Tach™ frame
- Cushioned lift and tilt cylinders
- Lift arm support
- Engine/hydraulics system shutdown
- Automatically activated glow plugs
- Electrically activated proportional front auxiliary hydraulics
- Auxiliary hydraulics: variable flow/maximum flow
- Machine IQ (telematic)
- Manual
- CE certification
- Warranty: 24 months or 2000 hours (whichever occurs first)

1. Roll Over Protective Structure (ROPS) – meets requirements of SAE-J1040 and ISO 3471; Falling Object Protective Structure (FOPS) - meets requirements of SAE-J1043 and ISO 3449, Level I

Options

- Factory Options
 - Deluxe pressurized cab with heating
 - Deluxe pressurized cab with HVAC
 - Selectable Joystick Controls (SJC - R/C Ready)
 - Tracks - rubber - 400 mm
 - Cloth Suspension Seat
 - High-flow auxiliary hydraulics
 - 7-pin attachment control
 - 2 Speed
 - Power Bob-Tach™
 - Back-up alarm
 - Radio
 - Beacon
 - Work Lights LED
 - Road Option
 - Automatic Ride Control
 - Automatic Reversing Fan
 - Custom paint color (min order of 5 units)
- Dealer Installed Options
 - Cab enclosure kit
 - Special applications front door kit
 - 200 lbs (74.4 kg) counterweight kit
 - Front axle counterweight kit
 - Fuel cap locking kit
 - Deluxe instrument panel
 - Replacement Bob-Tach™
 - Fresh air heater kit
 - Front door kit
 - Door sensor kit
 - Plumbing kit for fresh air heater
 - Back up alarm kit
 - FOPS kit **
 - Single-point lift kit
 - Power Bob-Tach™ kit
 - Operator cab, CE, enclosure kit
 - 7-pin attachment control
 - Four-point lift kit
 - Rear auxiliary hydraulic kit
 - Engine block heater kit
 - Road kit
 - Bucket positioning kit
 - Keyless kit
 - Rear window wiper kit
 - 14-pin attachment control kit
 - 4-Way flasher kit
 - 80 mm Suspension seat kit
 - Cup holder kit
 - Headlight guard kit
 - Muffler guard kit
 - Tail light guard kit

Attachments

- Auger Accessories
- Augers
- Backhoes
- Bale Forks
- Box Blades
- Breaker Accessories
- Breakers
- Brushcat™ Rotary Cutters
- Brush Saws
- Combination Buckets
- Concrete Mixers
- Concrete Pumps
- Construction / Industrial Buckets
- Diggers
- Dozer Blades
- Drop Hammers
- Dumping Hoppers
- Flail Cutters
- Forestry Cutters
- Graders
- Grapples, Industrial
- Landplanes
- Landscape Rakes
- Laser Equipment
- Low Profile Buckets
- Miscellaneous
- Mixing Buckets
- Mowers
- Pallet Fork Accessories
- Pallet Forks, Hydraulic
- Planer Accessories
- Planers
- Rear Stabilizers
- Remote Control
- Root Grapples
- Rotary Grinders
- Sand Cleaners
- Scarifiers
- Scrapers
- Seeders
- Skeleton Buckets
- Snow Blades
- Snow Pushers
- Snow V-Blades
- Sod Layers
- Soil Conditioners
- Spreader
- Spreaders
- Stump Grinders
- Sweepers
- Tillers
- Tilt-Tatch
- Tree Transplanters
- Trench Compactors
- Trenchers
- Utility Forks
- Utility Frames
- Vibratory Rollers
- Wheel Saws
- Wood Chippers

Environmental

Operator LpA (98/37 & 474-1)	82 dB(A)
Noise level LWA (EU Directive 2000/14/EC)	101 dB(A)
Whole body vibration (ISO 2631-1)	0.84 ms ⁻²
Hand-arm vibration (ISO 5349-1)	2.29 ms ⁻²

Safety

Bobcat Interlock Control System (BICS), standard	Requires the operator to be seated in the loader with the seat bar in place and the engine running. After the operator presses the “Press to Operate Loader” button, the loader's hydraulic lift and tilt functions and traction drive can be operated.
Lift arm bypass control, standard	Used to lower the lift arms in the event that the lift arms cannot be lowered during normal operating conditions.
Seat belt, standard	Should always be worn when operating the loader. Three-point shoulder belt provides restraint for high range speeds.
Seat bar, standard	Secondary operator restraint, also serves as an arm rest.
Operator cab, standard	An enclosed operator cab with side screens with a minimal inside cab width of 838 mm. Meets SAE-J1040 and ISO 3471 for Roll Over Protective Structure (ROPS) and SAE-J1043 and ISO 3449 Level I * for Falling Objects Protective Structure (FOPS). Level II ** option is available.
Lift arm support, standard	Use for servicing when lift arms are raised.
Parking brake, standard	Always set brake when leaving loader.
Grab handles, standard	Should always be used when entering/exiting loader.
Safety tread, standard	Slip resistant tread on lift arms and main frame to be used when entering/exiting loader.
Attachment steps, standard	Should always be used when entering/exiting loader.
Rear window, standard	For emergency exit.
Front and rear work lights, standard	Use for indoor and low light operation.
Back-up alarm, optional	For use in areas with high traffic
Lift kits, optional	Lift kits are available so loader may be lifted into remote areas.
Special applications kit, optional	Restricts objects and material from entering cab openings.
Operator handbook, standard	Weather-resistant operator handbook attached to the inside of the cab, providing operational instructions and warnings decals with pictorials and international symbols.