

# 9 Tonne Power Swivel

## KEY FEATURES & BENEFITS - MACH2297

**POWERSHIFT  
TRANSMISSION**



The Thwaites 9 Tonne Power Swivel, Stage V dumper is manufactured with contractors and hirers in mind – ensuring operator safety, reducing risk on site, and improving performance. The Power Swivel skip enables a 90° rotation left and right, allowing the machine easier access to tip loads in restricted areas, giving the operator greater control and reducing risk on site.

Powered by a 3.6L Deutz turbo diesel engine fitted with a DPF to comply with EU stage V emission regulations, you benefit from 55.4 kW peak power, 405 Nm of torque and no AdBlue requirement. The 9 Tonne Power Swivel is also available with a Powershuttle Transmission.

Thwaites 9 Tonne machines are available in a range of further configurations to suit your needs:

- › Front Tip
- › Front Tip with Cab

A Spring Activated Hydraulic Release (SAHR) Handbrake, 5" screen displaying 150° around machine visibility, hi-vis steps, LED road lights and twin LED beacons are available across the 9 Tonne range.

**Safe, compliant and competitive.**



Snap this QR code from your smart phone for more information



# Thwaites

Thwaites Ltd, Leamington Spa,  
Warwickshire, CV32 7NQ, England  
Tel +44 (0)1926 422471

[www.thwaitesdumpers.co.uk](http://www.thwaitesdumpers.co.uk)



**GET THE JOB DONE.**

# 9 Tonne Power Swivel

## DIMENSIONS & SPECIFICATIONS - MACH2297

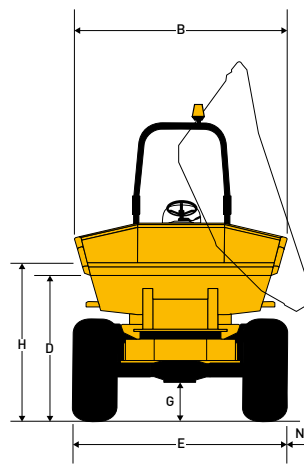
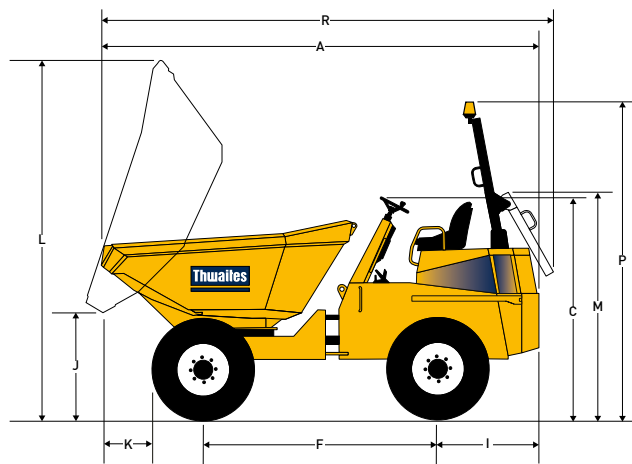

(mm)

<b>A</b>	5047	<b>N</b>	378
<b>B</b>	2435	<b>P</b>	3610
<b>C</b>	2540	<b>R</b>	5425
<b>D</b>	1820		
<b>E</b>	2440		
<b>F</b>	2660		
<b>G</b>	447		
<b>H</b>	2002		
<b>I</b>	1256		
<b>J</b>	1134		
<b>K</b>	1131		
<b>L</b>	4000		
<b>M</b>	2630		

<b>Weight</b>	Unladen	5710 kg
	Shipping	5666 kg

<b>Capacities</b>	Max safe load	9000 kg
	Heaped	4250 litres
	Struck	3400 litres
	Water	2050 litres

### Engine

- › Deutz TCD 3.6 L4, water-cooled, 4-cylinder, charged air cooled turbo, fuel injected diesel and after treatment Diesel Particulate filter
- › Power 55.4 kW/ 74 bhp at 2200 rpm
- › Torque 405 Nm (299 lbf ft).

### Noise Levels

- › Operator's ear 84 LpA / airborne level 101 LwA

### Transmission

- › Torque converter four speed forward and reverse Powershift transmission, column mounted speed and directional control lever

<b>Speeds</b>	Forward and Reverse	
	1	4.2 km/h (2.6 mph)
	2	7.5 km/h (4.6 mph)
	3	13.7 km/h (8.5 mph)
	4	24.3 km/h (15 mph)

### Brakes and Axles

- › Totally enclosed multiplate oil-immersed discs mounted on both axles & auto wear adjustment
- › Hand operated parking brake (SAHR)

### Kinglink Chassis

- › Constructed from folded steel plate, with three point Kinglink giving articulation and oscillation for better stability, traction and safety on site

### Skip

- › Hydraulically operated, 8 mm steel base plate
- › Skip mouth & sides reinforced with box sections
- › Power Swivel skip enables a 180° rotation

### Seating & Controls

- › Adjustable suspension seat with high-vis seat belt
- › Clear operators display unit contains all warning lamps

### Service Access

- › Lockable engine cover for ground level service points
- › Rear chassis panel can be hinged back on retainers

### Electrics

- › Fuse & relay are housed on a central power distribution board
- › Main harness is fully enclosed in solid conduit and incorporates the engine diagnostic port

### Steering and Hydraulics

- › Hydraulic power steering
- › Return line filtration for all services
- › Hydraulic test point fitted as standard

<b>Tank Capacities</b>	Fuel	72 litres
	Hydraulic	50 litres

<b>Turning Circle</b>	13.4m
-----------------------	-------

### Standard Equipment

- › Full LED road lighting incl. DRL (Daylight Running Lights)
- › Camera and dashpanel monitor
- › LED beacon
- › Fan guard
- › Reverse alarm

### Optional Equipment

- › Road mirrors
- › Wheel nut indicator
- › GPS speedometer

# Thwaites

Thwaites Ltd, Leamington Spa,  
Warwickshire, CV32 7NQ, England  
Tel +44 (0)1926 422471

[www.thwaitesdumpers.co.uk](http://www.thwaitesdumpers.co.uk)



Images are representative, but specific details or equipment may vary by country. We reserve the right to change any and all specifications without prior notice. 08/2021