

► SPECIFICATIONS

9 Tonne Front Tip

MACH2290

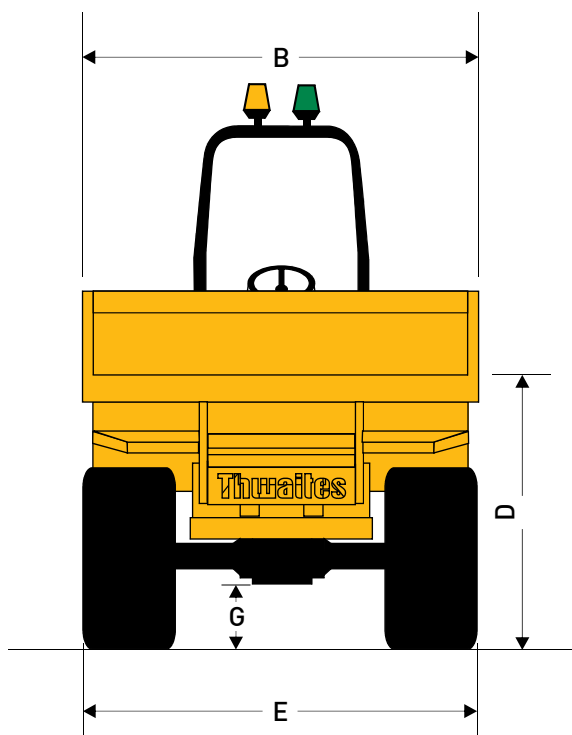
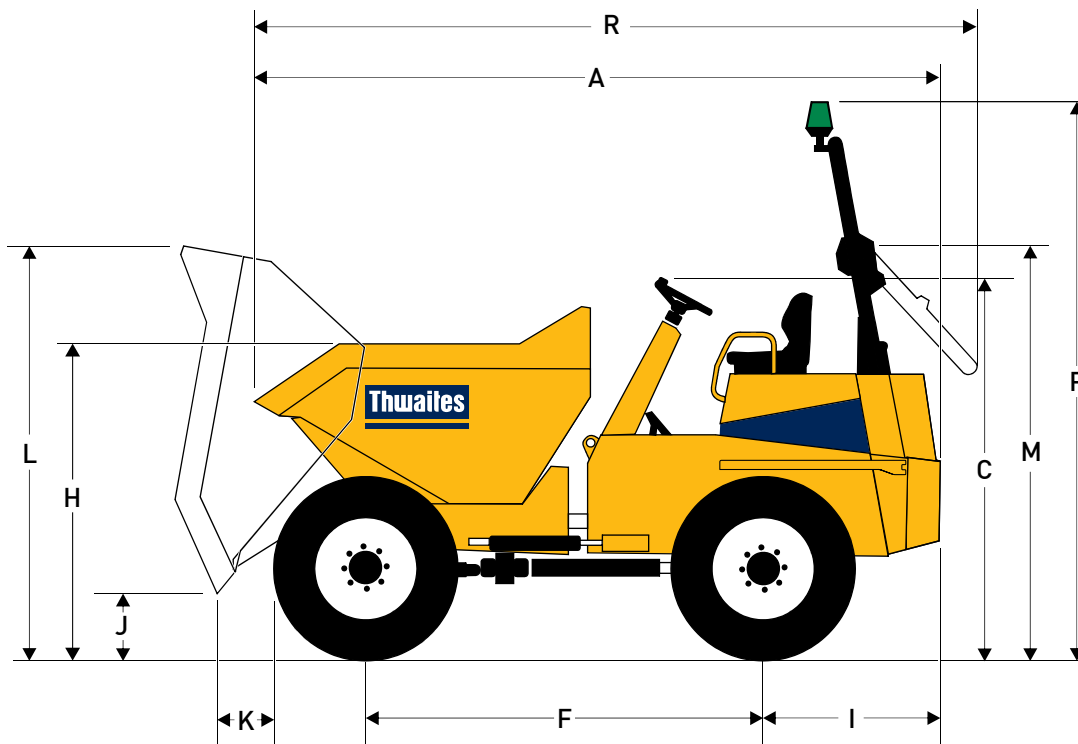

**Dimensions
(mm)**

A	4670
B	2485
C	2440
D	1740
E	2444
F	2615
G	447
H	1975
I	1255
J	436
K	642
L	2840
M	2555
P	3530
R	5014

► SPECIFICATIONS

9 Tonne Front Tip

MACH2290

Capacities	Max safe load	9000kg
	Heaped	4600 litres
	Struck	3830 litres
	Water	2155 litres

Engine

Deutz TCD 3.6 L4 55.4kW/74hp at 2200rpm, water-cooled, 4-cylinder, charged air cooled turbo, electronic controlled fuel injected diesel engine. Powercore air intake filter and stainless steel exhaust system, including after treatment Diesel Particulate filter providing conformity to EU Stage V emission regulations. Peak torque 405Nm at 1300 rpm.

Noise Levels

Operator's ear 84 LpA, airborne sound level 101 LwA

Transmission

Torque converter four speed forward and reverse Powershuttle transmission with column mounted directional control lever and heavy duty gear driven transfer box.

Speeds	Forward and Reverse	
	1	4.4km/h (2.7 mph)
	2	7.1km/h (4.4 mph)
	3	13.3km/h (8.3 mph)
	4	24.3km/h (15 mph)

Tyres	500/60 x 22.5
	Track grip tread
	Load/Speed Index 149 A8

Brakes and Axles

Twin circuit totally enclosed multiplate oil immersed discs, mounted on both axles with automatic adjustment for wear. Hand-operated parking brake, spring applied hydraulically released brakes (SAHR). Heavy duty axles with epicyclic reduction and fully floating half shafts.

Kinglink Chassis

Front and rear chassis constructed from deep section folded steel plate, with three point Kinglink giving articulation and oscillation for better stability, traction and extra safety on site. Remote greasing point provided for lubrication of top Kinglink articulation pin.

Skip

Hydraulically operated, 6 mm steel base plate, fully welded, mouth and sides of skip reinforced with box sections giving greater strength to minimise skip damage. No material traps. Optional abrasion resistant steel plate (AR400) for skip base, rear and front panel sections.

Seating & Controls

Adjustable suspension seat, fitted with high visibility rigid seat belt with adjustable web, accessible from both sides. Audible warning device for handbrake in "on" position, electric horn, large pedal pads, ignition key, park brake and skip controls ready to hand. Clear operators display unit contains all warning lamps plus LED screen to show Fuel level, Hourmeter, Tachometer, Engine coolant temperature, Error codes and description should an engine error occur.

Service Access

Lockable three sided cover opens to provide easy access from ground level to engine service points, all located on the same side. Rear chassis panel can be hinged back on retainers. An additional service access door incorporates the battery. Moulded plastic diesel tank and steel hydraulic tank are positioned low in chassis side members, permitting access to the filler caps from ground level.

Electrics

Engine control unit (ECU) monitors all engine/emission related systems, if necessary, reducing engine power/speed (including engine shut-down). Fuse & relay are clearly marked and housed on a central power distribution board. Main harness is fully enclosed in solid conduit and incorporates the engine diagnostic port.

Steering and Hydraulics

Single gear pump providing hydraulic functions includes priority power steering. Filter mounted on top of the tank accessible from ground level. Hydraulic test point fitted as standard.

Tank Capacities	Fuel	72 litres
	Hydraulic	50 litres

Shipping Cube	31.8 m ³ (with ROPS)
----------------------	---------------------------------

Unladen Weight	4820kg
-----------------------	--------

Clearance Diameter	14m
---------------------------	-----

Standard Equipment

Camera and Dashpanel Monitor, Towing bracket, Folding ROPS frame, LED Beacons (Amber) & (Green), Fan guard, Low fuel level warning, Water in fuel warning, Low Brake Fluid warning, High visibility rigid seat belt, Reverse alarm.

Optional Extras

Full LED road lighting Incl. DRL (Daylight Running Lights), Road mirrors, Wheel Nut Indicator, GPS Speedometer, Trackunit.



Thwaites Ltd. Leamington Spa, Warwickshire CV32 7NQ, England
 Tel +44 (0)1926 422471 Fax +44 (0)1926 337155
 www.thwaitesdumpers.co.uk



We reserve the right to change all specifications without prior notice. Printed in England 10/2019