

432F

Backhoe Loader



Cat® C4.4 ACERT™ Engine*

	Standard	Optional
Gross Power (ISO 14395) @ 2,200 rpm	74.5 kW (101 hp)	82 kW (111 hp)
Net Power (ISO 9249) @ 2,200 rpm	69.9 kW (95 hp)	77.5 kW (105 hp)

*EU Stage IIIB Emission Standards.

Weights

Operating Weight	8973 kg
------------------	---------

Backhoe Digging Depth

Digging Depth, SAE Maximum	
Standard Stick	4278 mm
E-Stick Retracted – 4.26 m	4281 mm
E-Stick Extended – 4.26 m	5274 mm
E-Stick Retracted – 4.87 m	4613 mm
E-Stick Extended – 4.87 m	5643 mm

Contents

Features.....	4
Engine and Driveline.....	6
Operator Environment.....	8
Loader.....	10
Backhoe.....	11
Hydraulics.....	12
Work Tools.....	13
Serviceability.....	14
Customer Support.....	15
Specifications.....	16
Standard Equipment.....	21
Optional Equipment.....	22





Building on the success of the F Series, Cat Backhoe Loaders now incorporate the latest in clean engine emissions technology, which meets EU Stage IIIB emission standards.

With a host of new features that deliver improved fuel economy, introduced with the new electronic engine, and unobstructed visibility thanks to an A-post mounted exhaust stack, this is no mere engine update.

Electronic Hydraulic Control Pump

Delivering up to 5% fuel savings, faster control response, and accurate hydraulic fluid management.

Service Diagnostics

Enhanced machine monitoring tracks faults, displaying fault codes on the new LCD display screen. By detailing the fault code, your dealer will be fully aware of the issue, ensuring they have the correct parts for the job, getting you back to work as quickly as possible.

New Hydraulic Quick Coupler

Easy interchanging of backhoe work tools, the new powered coupler engages tools hydraulically, so you can switch tools from the comfort and safety of the seat.

Lock-up Torque Converter

With a 16% increase in fuel efficiency and 11% higher average speed, the lock-up torque converter is an invaluable addition for those traveling between sites.

Larger Torque Converter

A 2.4:1 torque converter in the 432F delivers up to 14% greater pushing power and improved roading and hill climbing performance when compared to its predecessor.

Extreme Conditions

Our proven engines are tried and tested in the harshest environments. Dependant on regional requirements, our machines can be equipped to handle extreme cold and extreme heat (up to 50° C).

Air Filter

A dry type axial air cleaner with an integral precleaner and automatic integrated dust ejection system extends the life of the air filter when working in dusty conditions, reducing service time and costs.

Storage

Having somewhere to keep your tools is important on any machine, and that is why on the 432F we provide plenty of storage space in a secured external storage box.

Large Fuel Tank

A large 160 L non-metallic fuel tank in combination with the Cat engine and efficient hydraulic system ensures longer periods between fill ups and less inconvenience. The composite material prevents rust forming in the tank, protecting fuel injection components.





Features

Designed with you in mind.

Engine and Driveline

Dynamic, powerful and proven.





New C4.4 ACERT Engine

Meeting the new EU Stage IIIB emission standards, our new electronic C4.4 ACERT engine delivers a host of features and improvements.

Power Boost

For operators looking for more power, the C4.4 ACERT engine delivers up to 82 kW (111 hp), and 10% more torque.

Passive DPF System

Service free diesel particulate filter requires no operator interaction, with built-in self-cleaning. That's just one less thing to think about.

Automatic Engine Speed Control (AESC)

Reduces engine speed automatically to low idle when the system detects an operator hasn't engaged the controls for a short period, reducing fuel consumption.

Manual Low Idle

Engage instant engine low idle at the touch of a button, reducing fuel consumption if waiting on a truck, or reduce engine speed to communicate. Simply tap to go again.

Axles and Differential Lock

The heavy duty Cat axles fitted to the 432F have been designed to be used in the most arduous of conditions and the rear axle Differential Lock ensures that traction is maintained in all types of ground conditions.

Boosted Braking

Assisted brakes provide less pedal effort, for safer, more efficient braking. Dual brake pedals can be split for braking in tight corners.

Auto-shift Transmission

This optional five-speed transmission will perfectly match itself to the application, carefully selecting the appropriate gear whether you're driving between job sites or charging into hard bank. To take full control of any situation, you can choose to select a gear manually with a simple twist of a hand lever. The spacing of the gears optimizes shift comfort, for exceptionally smooth acceleration.

Excavator Style Controls

For smooth and precise control of the backhoe, the joystick controls, fitted as standard on the 432F, are the perfect solution for those looking for premium comfort.

Dual Position Joystick Pods

The joysticks are pod-mounted, with two location positions. Sit back in comfort with the controls by your side, or lean forward with the controls for a view of the trench close-up to the machine.

Drive Control

Switch between 2 wheel drive (2WD) and all wheel drive (AWD) using the three position drive selector. A third mode, 2WD with all wheel braking, activates AWD when braking and returns to 2WD when brake pedal is released, ensuring positive braking effort in hazardous driving conditions, and reduces tire wear.

Pattern Selector

The pattern selector switch, located in the cab, lets you change from an excavator to a backhoe control pattern simply by pressing a button. This lets you select the pattern you are most comfortable with so you can be more productive.

Air Suspension Seat

The major interface between the machine and the operator, the air suspension seat, fitted as standard, provides the operator with a comfortable working platform to ensure high levels of productivity with the minimum of fatigue.

Cab Cooling

The 432F can be equipped with a powerful air conditioning system, which ensures the operator stays cool when working in warm temperatures. The ventilation system also provides plenty of demisting, defrosting and heating capability.



Operator Environment

Get the job done in comfort and style.





Loader

The parallel lift loader reaches new heights.

Loader Performance

Designed with performance in mind, the 432F has higher breakout forces, load over height and reach, making life easier for you when truck loading or shoveling. Parallel Lift Loader arms offer self-leveling as standard, providing safe lifting of any palletized load. Versatility is enhanced with the choice of a General Purpose or Multi Purpose bucket, and visibility is excellent, the lower hood line enabling a clear line of sight to the top of the bucket.

Ride Control

The Cat proven Ride Control system is an option designed to reduce machine pitching and bouncing giving operators a smooth ride in all applications, including load and carry, roading, or simply moving around the job site. The system is engaged by a switch on the front console.

Return to Dig

The 432F is equipped with a Return-to-Dig system, as standard. This system reduces loading cycle times by bringing the loader bucket back to the dig position automatically when lowering the arms. By the time the loader arms have been lowered to ground level, the bucket is in the correct position ready for the next load.

Hydraulic Loader Quick Coupler

The 432F is available with an optional loader quick coupler, allowing greater loader versatility with a wide range of Cat work tools increasing machine utilization on any work site.



Backhoe

Serious power in the dirt.

Excavator-Style Backhoe

Whether close-up truck loading on a single road carriageway, or digging over obstacles such as walls, the 432F backhoe tackles the toughest jobs with ease. Combine the versatility with the powerful breakout forces, the controllability of the load sensing, flow-sharing hydraulic system and the 432F is capable of producing high levels of productivity with the minimum of operator effort. The boom is a narrow design, ensuring maximum visibility to the work tool.

Extendible Stick

The 432F is available with an optional extendible stick that increases dig depth and reach capability increasing the machines versatility and utilization. A sliding inner section design keeps the wear pads out of the dirt, extending adjustment and replacement intervals. Auxiliary lines, for operating work tools, have been routed so that they are protected from damage when working in the narrowest of trenches.

Slider Frame and Swing Frame

Designed to make necessary maintenance easier to perform, the F Series cast slider frame has exterior lock clamps, with no backhoe disassembly needed when servicing. The Swing Frame/Boom Foot pins have replaceable bushings in the bores.

The 432F is equipped with Cat Cushion Swing, which enables very fast trenching by damping the boom oscillation down when returning to trench with the hoe.

Powered Side Shift (Optional)

Provides a hydraulic service to enable the operator to easily position the backhoe across the full width of the H-frame without the need to place the bucket on the ground. Ideal for use in utility applications such as gas, electrical, telecoms, etc.



Hydraulics

Fuel efficient, powerful and reliable.

Load Sensing Hydraulics

It's rare that you'll be working at full production 100% of the time. So why should the machine be working flat out, using more fuel, making more noise, and increasing wear?

The 432F has a load-sensing, closed center hydraulic system, which actively matches hydraulic power and flow to meet the demand needed by the task being performed. So whether you're trenching at full force, or delicately digging around services, you are in total control.

As there is minimal demand on the system unless needed, there are less parasitic power losses, unlocking the true potential of the engine – providing better loading and roading performance.

Flow-Sharing Valves

The 432F features flow-sharing hydraulic valves, ensuring that the correct flow of oil reaches the implement cylinders, providing greater control and eliminating oil starvation when operating multiple functions, such as grading with the backhoe.

Hardware

The 432F is equipped with a highly efficient variable displacement piston pump. Reliable high performance hydraulic hose is constructed from two strong steel braided layers and O-Ring face seal fittings provides a robust system ensuring excellent durability and resistance to damage from pressure spikes and hydraulic pulsing.

Work Tools

An array of tools at your fingertips.

The Backhoe Loader can be found in many different applications, and sometimes a bucket just won't do. Discuss your needs and wants with your dealer, and they will be able to recommend the right tool for the right application, giving you a tailored machine that's perfectly matched to your needs.

Loader Buckets

General Purpose and hydraulic Multi Purpose buckets are either Pin-on mounted or attached to the quick coupler. They can be fitted with either cutting edge or bolt on teeth. MP buckets are optional with fold over pallet forks.

Backhoe Buckets

For different soil types and digging applications there are multiple bucket designs available, including; Standard Duty, Heavy Duty, High Capacity and Extreme Service (Rock) Buckets. Either bolt on teeth or weld on adapters with pin on teeth can be fitted. Ditch Cleaning, Cribbing and Trapezoidal Buckets are also available.

Auger

The Cat Auger is designed for drilling holes in the earth for a wide variety of applications. A wide variety of Auger bits and drive systems are available, to provide you with the best tool for the job.

Cold Planer

The Cat Cold Planer is designed for both asphalt and concrete planing work, having features like depth control and self-leveling.

Compactor Plate

The Cat Vibratory Plate Compactor can be used to compact soil, sand or gravel in trenching and sloping applications prior to pouring concrete or laying asphalt.

Hammer

Cat Hydraulic Hammers are designed to break up concrete, asphalt or rock and deliver constant power when operated. Silenced options are available to meet with local regulations.



Serviceability

Get straight to work.



Effortless Maintenance

Make light work of daily checks, with the remodeled front nose, which swings open to reveal a hinged cooling pack for debris removal, keeping cooling performance to an optimum.

All daily check points such as; fill points, air cleaner, washer bottles, indicators etc. are found above the engine bay, accessed with a simple release of the engine hood, removing the stresses of access in-and-amongst the engine bay.

Sealed for life axles and driveshafts remove the need for operators to grease the time-consuming, awkward areas below the machine.

Daily maintenance, which can be a chore for the busy operator, is kept to a minimum on the 432F.

Wear Pad Adjustment

The stabilizers and backhoe are designed to allow all wear pad adjustment to be done in-situ, using a simple adjustment mechanism. When wear pad adjustment is necessary, the adjustment bolts are easy to access, taking minutes to adjust, without the need for disassembly.

Cat Filters

All Cat filters are vertically mounted for spill free servicing and reduced oil contamination. These low micron filters remove microscopic particles from the oil, keeping the engine, transmission and hydraulic system running smoothly for years.

Electro-Deposition Coating

The 432F is protected by an undercoat of electro-deposited (E-Coat) primer, which completely seals each metallic component and offers a superlative degree of protection from damage and corrosion. Coupled with the high solids polyurethane top coat, the 432F will remain in prime condition for longer, ensuring optimum resale value.

Customer Support Agreements (CSA's)

Your Cat dealer can offer a comprehensive range of CSA's which can be individually tailored to suit your finances and requirements. Dealers can offer a range of options from a full Preventative Maintenance with S·O·SSM package to a Parts Only CSA. Protect your valuable investment and know exactly what your monthly payments will be to help you run your business.

Finance

Have you explored the range of options available from your dealer to finance your machine? They can offer a selection of attractive packages tailored exactly to your requirements.

Machine Selection

Your dealer can help guide you with your machine purchase decision, based on your requirements and help keep operating costs to a minimum. Is the machine you have in mind exactly the best for your job, or could other attachments be more suitable?

Scheduled Oil Sampling

Your Cat dealer will be able to provide the Cat S·O·S. This enables your dealer to analyze wear before problems arise, so that premature failure can be avoided, and corrective action can take place to reduce costs and downtime.



Customer Support
Always there for you.

432F Backhoe Loader Specifications

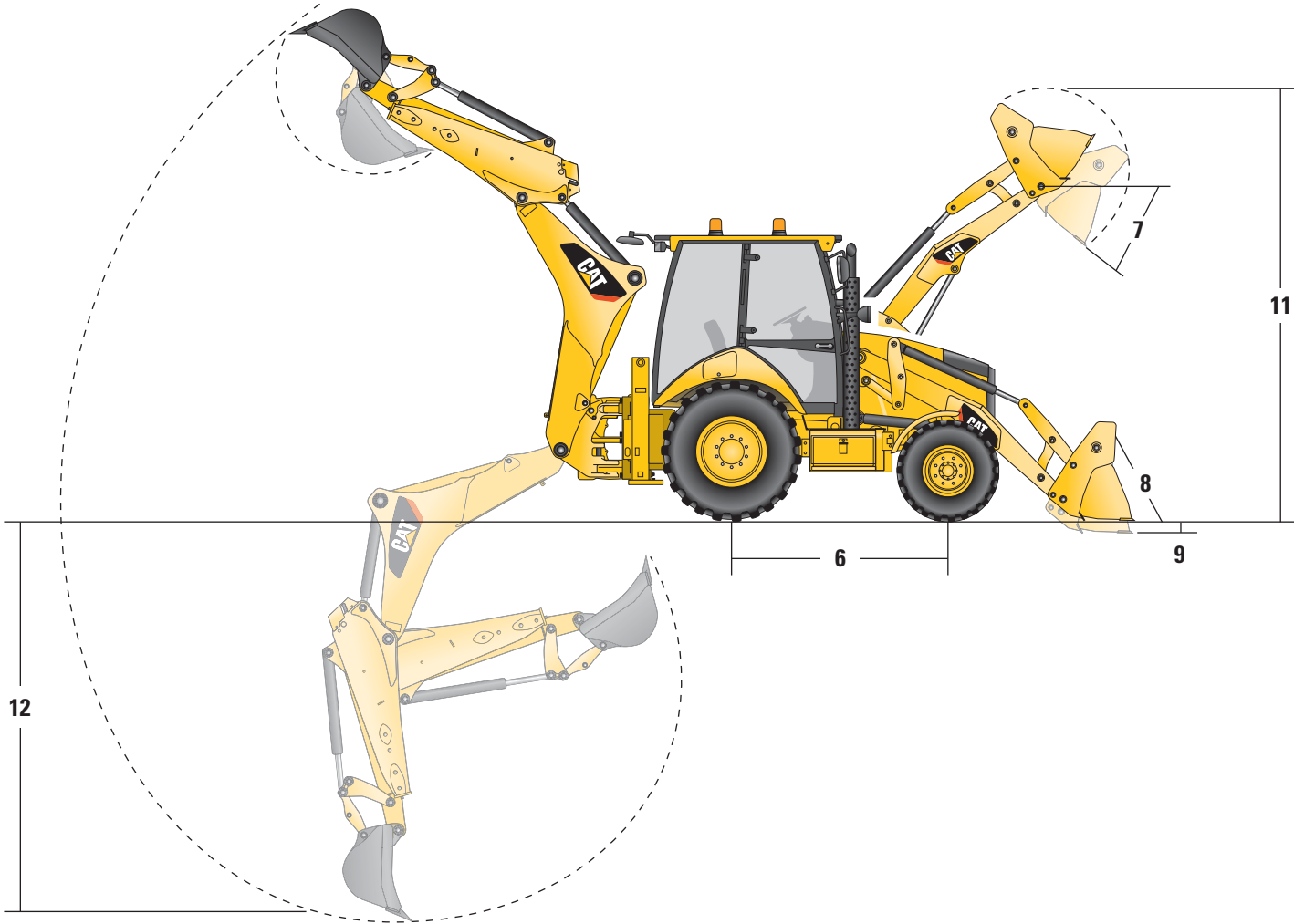
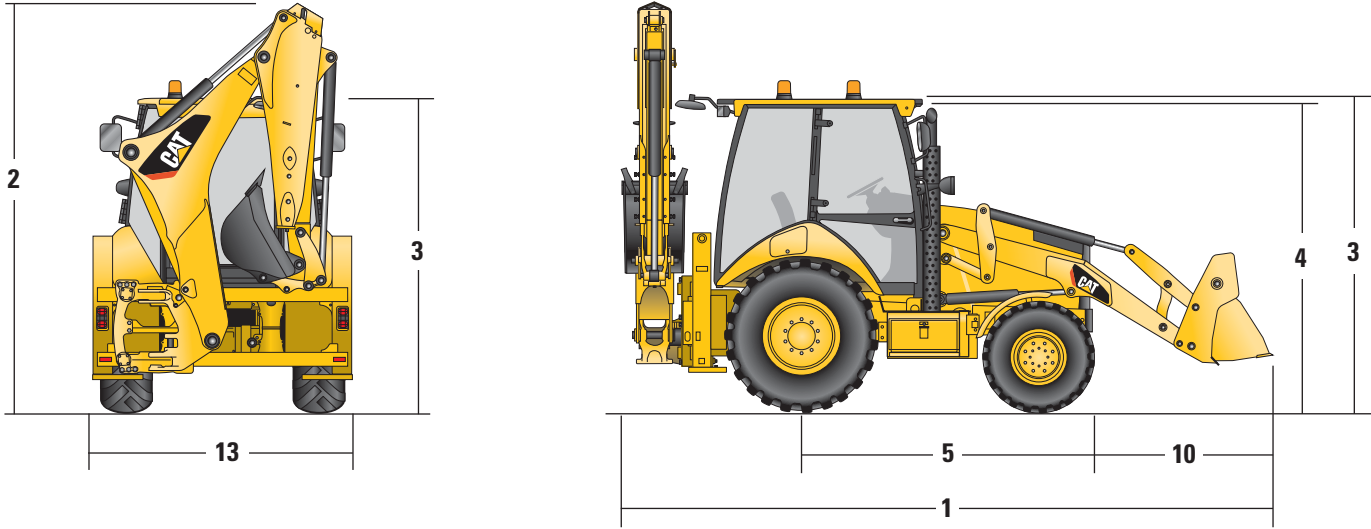

Machine Dimensions

	GP	MP	MP with forks
Overall length (loader on ground, hoe swung out)	7398 mm	7353 mm	7353 mm
1 Overall length in roading position	5744 mm	5714 mm	5714 mm
Overall transport length	5750 mm	5704 mm	5704 mm
2 Overall transport height	3779 mm	3779 mm	3779 mm
Overall width	2352 mm	2352 mm	2352 mm
3 Height to top of cab	2897 mm	2897 mm	2897 mm
4 Height to top of exhaust stack	2744 mm	2744 mm	2744 mm
Ground clearance (minimum)	320 mm	320 mm	320 mm
5 Rear axle centerline to front grill	2705 mm	2705 mm	2705 mm
Front wheel tread gauge	1895 mm	1895 mm	1895 mm
Rear wheel tread gauge	1714 mm	1714 mm	1714 mm
6 Wheelbase 2WD/AWD	2200 mm	2200 mm	2200 mm

Dimensions and Performance – Loader

	GP	MP	MP with forks
Capacity (SAE rated)	1.00 m ³	1.03 m ³	1.03 m ³
Width	2406 mm	2406 mm	2406 mm
Breakout force	54.9 kN	60.4 kN	59.5 kN
Lift capacity at maximum height	3817 kg	3580 kg	3402 kg
Tipping load at breakout point	6804 kg	6790 kg	6641 kg
Dump height at maximum angle	2796 mm	2823 mm	2823 mm
Dump reach at maximum angle	805 mm	731 mm	731 mm
Maximum hinge pin height	3497 mm	3497 mm	3497 mm
7 Dump angle at full height	46°	46°	46°
8 Maximum bucket rollback at ground level	38°	39°	39°
9 Digging depth	61 mm	94 mm	94 mm
Maximum grading angle	113°	116°	116°
Width of dozer cutting edge	—	2406 mm	2406 mm
10 Grill to bucket cutting edge, carry position	1471 mm	1423 mm	1423 mm
11 Maximum operating height	4394 mm	4427 mm	4883 mm
Jaw opening maximum	—	790 mm	790 mm
Bucket jaw clamping force	—	61 kN	61 kN
Weight (does not include teeth or forks)	428 kg	611 kg	705 kg

Dimensions and Performance – Backhoe

	Standard Stick	E-Stick Retracted – 4.26 m	E-Stick Extended – 4.26 m	E-Stick Retracted – 4.87 m	E-Stick Extended – 4.87 m
Digging depth, SAE Maximum	4278 mm	4281 mm	5274 mm	4613 mm	5643 mm
Digging depth, manufacturer's maximum	4775 mm	4814 mm	5730 mm	5238 mm	6199 mm
12 Digging depth, 610 mm flat bottom	4235 mm	4239 mm	5235 mm	4589 mm	5611 mm
Reach from swing pivot at ground line	5650 mm	5655 mm	6583 mm	6127 mm	7078 mm
Reach from rear axle centerline at ground line	6740 mm	6745 mm	7670 mm	7217 mm	8168 mm
Maximum operating height	5691 mm	5692 mm	6297 mm	6254 mm	6984 mm
Loading height	4016 mm	4025 mm	4630 mm	4579 mm	5309 mm
Loading reach	1669 mm	1617 mm	2475 mm	1535 mm	2289 mm
Swing arc	180°	180°	180°	180°	180°
Bucket rotation	205°	205°	205°	205°	205°
13 Stabilizer (overall width)	2352 mm	2352 mm	2352 mm	2352 mm	2352 mm
Bucket dig force	63.5 kN	63.4 kN	63.4 kN	63.4 kN	63.4 kN
Stick dig force	45.3 kN	46.3 kN	31.8 kN	47.3 kN	36.7 kN

432F Backhoe Loader Specifications

Engine

Engine Model	Cat C4.4 ACERT*
Rated Power (Standard)	2,200 rpm
Gross – ISO 14396	74.5 kW/101 hp
Net – ISO 9249	69.9 kW/95 hp
Net – 80/1269/EEC	69.9 kW/95 hp
Rated Power (Optional)	
Gross – ISO 14396	82 kW/111 hp
Net – ISO 9249	77.5 kW/105 hp
Net – 80/1269/EEC	77.5 kW/105 hp
Net Torque Rise @ 1,400 rpm	
82 kW/111 hp	32%
74.5 kW/101 hp	46%
Peak Torque @ 1,400 rpm	
82 kW/111 hp	450 N·m
74.5 kW/101 hp	450 N·m
Bore	105 mm
Stroke	127 mm
Displacement	4.4 L

- Net power advertised is the power available at the flywheel when the engine is equipped with fan, air cleaner, muffler and alternator.
 - No derating required up to 3000 m (10,000 ft) altitude. Auto derate protects hydraulic and transmission systems.
- *Stage IIIB EU Emission Standards.

Features

- Three ring pistons made of lightweight silicon/aluminum alloy for strength and maximum thermal conductivity.
- Poly vee front end and auxiliary drive belt that is automatically tensioned for long life reducing operating costs.
- Direct injection fuel system provides accurate fuel delivery. Self priming electric lift pump for improved cold start capability. One filter fuel system for reduced maintenance costs.
- High torque at low engine speeds for fuel efficient performance.
- Dry type, axial seal air cleaner with automatic, integrated dust ejection providing more efficient pre-separation.
- Direct electric 12 volt starting and charging system with 750 CCA group 31 maintenance free battery.

Axles

Standard All Wheel Drive.

Features

- Heavy-duty rear axle with self adjusting inboard brakes, differential lock and final drives.
- All Wheel Drive (AWD) is engaged by front console panel switch or by brake pedal during all-wheel-braking operation. AWD can be engaged on-the-go, under load, in any gear, forward or reverse. AWD has outer final drives for easy maintenance.
- AWD front axle is pendulum mounted and permanently sealed and lubricated, requiring no daily maintenance. Also features double-acting steering cylinder with 52° steering angle for increased maneuverability.

Steering

Full hydrostatic steering controlled by a hand-metering unit. Secondary steering system available to meet roading regulations in various countries and to meet ISO 5010.

Steering

Type	Front Wheel
Power Steering	Hydrostatic
Cylinder, One (1) AWD	
Bore	65 mm
Stroke	120 mm
Rod Diameter	36 mm
Turning Circle	
Inner Wheel Not Braked (4WD)	
Outside Front Wheels	8180 mm
Outside Widest Loader Bucket	10 970 mm

Brakes

Fully enclosed boosted, hydraulic, multiple discs.

Features

- Inboard oil-immersed, hydraulically actuated multiple Kevlar discs on final drive input shaft.
- Completely enclosed and sealed.
- Self-adjusting.
- Dual foot-operated boosted brake pedals can be interlocked for roading.
- Parking/secondary brakes are independent of the service brake system. Parking brake is mechanically applied through a hand lever located in the right side console.
- Meets ISO 3450:1996 requirements.

Weights

Standard parallel lift loader, with 1.03 m³ multi purpose loader bucket with forks, 610 mm standard duty backhoe bucket, 115 kg counterweight, 75 kg operator, and a full fuel tank.

Weights

Machine Weight* (Range)	7620-10 817 kg
Operating Weight**	8973 kg
Auto-shift	27 kg
Air Conditioning	39 kg
Ride Control	25 kg
Multi Purpose Bucket	1.03 m ³
with Fold-Over Forks	842 kg
without Fold-Over Forks	611 kg
Extendible Stick (Excludes Front Counterweight)	299 kg
Counterweights	
Light	115 kg
Medium	250 kg
Heavy	485 kg

Minimum Counterweight Recommendations:

Standard Stick	
General Purpose	250 kg
Multi Purpose	None
Extendible Stick	
General Purpose	485 kg
Multi Purpose	115 kg

*Machine weight (range) denotes minimum configuration to maximum configuration weight.

**Operating weight denotes the weight of the machine for a common configuration (as seen above).

Cab Features

	Standard	Deluxe
Full Glazing	✓	✓
RH Opening Door with Opening Window	✓	✓
LH Opening Door with Opening Window	✓	✓
2 Rear Side Fixed Windows	✓	
2 Rear Side Opening Windows		✓
Standard Air Suspension Seat	✓	
Deluxe Air Suspension Seat		✓
8 Working Lights (4 front, 4 rear)	✓	✓
Floor Mat	✓	✓
LH Storage Console	✓	✓
Tilt Steering Column	✓	✓
Exterior Rearview Mirror	✓	✓
Beacon Socket (2)	✓	✓
Internal Power Socket	✓	✓
Radio Ready Headliner	✓	✓
Premium Gauge Cluster	✓	✓
Sun Visor	✓	✓
Seat Belt (50 mm)	✓	✓
Steering Wheel Knob	✓	✓
Vandal Guard	✓	✓
Cab Heater	✓	✓
Cab Air Conditioning	optional	optional
Auto-Up Stabilizers	✓	✓

Operator Station

ROPS/FOPS is standard.

ROPS (Roll Over Protective Structure) offered by Caterpillar for this machine meets ROPS criteria ISO 3471:1994 and FOPS (Falling Objects Protective Structure) criteria ISO 3449:1992.

432F Backhoe Loader Specifications

Service Refill Capacities

Cooling System	
with Heater	22 L
Fuel Tank	160 L
Engine with Oil Filter	8.8 L
Transmission	
Power Shuttle AWD	18 L
Rear Axle (Rigid/Steerable)	
Center Housing	16.5 L
Wheel End/Final Drive (Volume per Side)	1.7 L
Front Axle AWD	
Center Housing	11 L
Wheel End/Final Drive (Volume per Side)	0.7 L
Hydraulic System	95 L
Hydraulic Tank	40 L

Hydraulic System

Load-sensing, closed-center system.

Variable-flow, closed-center load-sensing system provides full hydraulic force to cutting edges at all engine speeds. Provides low fuel consumption and low effort controls.

Type	Closed-center
Pump Type	Variable-flow, axial-piston
Pump Capacity	156 L/m @ 2,200 rpm
System Pressure	
Backhoe	250 bar
Loader	250 bar

Transmission

The standard power-shuttle transmission provides four speed forward and reverse, full synchromesh in all gears. The optional auto-shift transmission can be operated in automatic or manual mode.

	Power-shuttle	Auto-shift
Forward		
1st	6 km/h	6 km/h
2nd	9.7 km/h	9.6 km/h
3rd	20 km/h	20 km/h
4th	40 km/h	27.4 km/h
5th	—	40.9 km/h
Reverse		
1st	6 km/h	6 km/h
2nd	9.7 km/h	12.6 km/h
3rd	20 km/h	27.6 km/h
4th	40 km/h	—
5th	—	—

Lock-up Torque Converter

The optional lock-up torque converter is automatically selected dependent on ground speed and enables speed to be maintained longer over all types of terrain.

Standard Equipment

Standard equipment may vary. Consult your Cat dealer for details.

- Air cleaner, axial seal with precleaner and filter condition indicator
- Alarms
 - Reversing
 - System fault/alert
- All Wheel Drive
- Alternator, 120-amp, 12 volt
- Antifreeze (to –37° C)
- Automatic engine speed control (AESC)
- Backhoe, joystick (Pilot) controls
- Battery isolator
- Battery, maintenance free, 750 CCA
- Boom, transport lock
- Brace, lift cylinder
- Brakes, hydraulically boosted, oil disc, dual pedals, interlocking
- Coat hook
- Dome light (cab only)
- Diesel particulate filter (DPF), long life
- Eco drain
- Electro-hydraulic slide frame lock
- Engine, Cat C4.4 ACERT* (74.5 kW)
- Engine enclosure, quick release
- Fan, cooling and fan guard
- Flashing hazard/signal lights
- Floor mat, rubber
- Front grill, impact absorbing with bumpers
- Front headlights
- Gauge cluster
 - Gauges; coolant temperature, fuel level, tachometer
 - LCD screen; hour meter, torque converter oil temperature, hydraulic oil temperature, operator settings, service mode diagnostics
- Ground line fuel fill with 160 L capacity
- High ambient cooling package
- Hinged cooling pack
- Hydraulic oil cooler
- Hydraulic system, load sensing, variable flow system with axial piston pump
- Hydraulic suction strainer
- Instrument panel lights
- Intermittent front and rear wash/wipe
- Lifting eye, backhoe (non EU countries only)
- Lights, working (4 front, 4 rear)
- Manual low idle
- Mirrors, external (2)
- O-ring face seal hydraulic fittings
- Power receptacles, 12V (2 external, 1 internal)
- Power steering, hydrostatic
- Return to Dig
- ROPS cab with heater, defroster, pressurizer and cab recirculating fan
- Seat, air suspension with fabric seat cover
- Seat belt, retractable (50 mm)
- Self-cancelling directional indicator
- Spin-on fuel, engine and transmission oil filters
- Stick, standard (4.26 m)
- Starting system, thermal aid
- Steering wheel knob
- Stop and tail lights (2)
- Storage box, external, lockable
- Sun visor
- Swing transport lock
- Throttles, hand (rotary dial) and foot pedal
- Tilt steering column
- Tires (2 front, 2 rear)
- Torque converter
- Transmission, four-speed synchromesh
- Transmission neutralizer switch
- Transport tie-downs
- Vandalism guard
- Warning horn, front electric
- Water separator

*Stage IIIB EU Emissions Standards.

432F Optional Equipment

Optional Equipment

Optional equipment may vary. Consult your Cat dealer for details.

- Air conditioning
- Attachments, backhoe work tools
 - Quick Coupler (mechanical)
 - Quick Coupler (hydraulic)
- Attachments, front loader
 - General purpose bucket 1.0 m³
 - Multi purpose bucket 1.03 m³ or 1.03 m³ with forks
- Auto-shift transmission
- Battery, additional
- Battery, remote jump start
- Counterweights
 - 115 kg
 - 250 kg
 - 485 kg
- Cutting edge, bolt on
 - Single piece
 - Two piece
- Engine, Cat C4.4 ACERT* (82 kW)
- Fenders, front
- Guards
 - Driveshaft
 - Teeth (GP/MP)
 - Rear lights
- Hoe continuous flow
- Hydraulic lines
 - Hammer lines to extendable stick
 - Quick disconnects
- Hydraulic valves (auxiliary)
 - Extendible stick
- Hydraulic valves, loader
 - 3rd valve for GP/MP
- Lights
 - Number plate, rear
 - Roading
- Lock-up torque converter (only available with auto-shift transmission)
- Mirror, exterior rearview, large
- Object handling installation, including lifting eye, boom and stick locks, audible and visual warning system
- Operator's station
 - Deluxe cab
- Powered side shift
- Product Link
- Ride control
- Rotating beacon
- Stabilizer street pads
- Stick, extendible (4.26 m)
- Stick, extendible (4.87 m)

*Stage IIIB EU Emissions Standards.

For more complete information on Cat products, dealer services, and industry solutions, visit us on the web at www.cat.com

AEHQ7110 (09-2013)

© 2013 Caterpillar Inc.
All rights reserved

Materials and specifications are subject to change without notice. Featured machines in photos may include additional equipment. See your Cat dealer for available options.

CAT, CATERPILLAR, SAFETY.CAT.COM, their respective logos, "Caterpillar Yellow" and the "Power Edge" trade dress, as well as corporate and product identity used herein, are trademarks of Caterpillar and may not be used without permission.

