



Slurry Tankers & Applicators



- Sprung drawbar
- 24" Galvanised rear access hatch
- Full L.E.D. lighting c/w high level rear clusters.
- Galvanised suction hose hanger brackets (on one side)
- Four inlets, one at each corner. One fitted with manual gate valve c/w over centre handle, greasing point & Quick attach coupling. Others fitted with galvanised blanking plates.
- 6mm plate barrel
- 6" diameter 6m suction hose as standard
- Dual sided manual vacuum pump change over
- Hydraulic braking via two cylinders per axle
- Ratchet style handbrake
- Tank braced internally (Internal tank baffles to BS EN 707: 2018)
- Two pack paint finish
- Sight glass front and rear



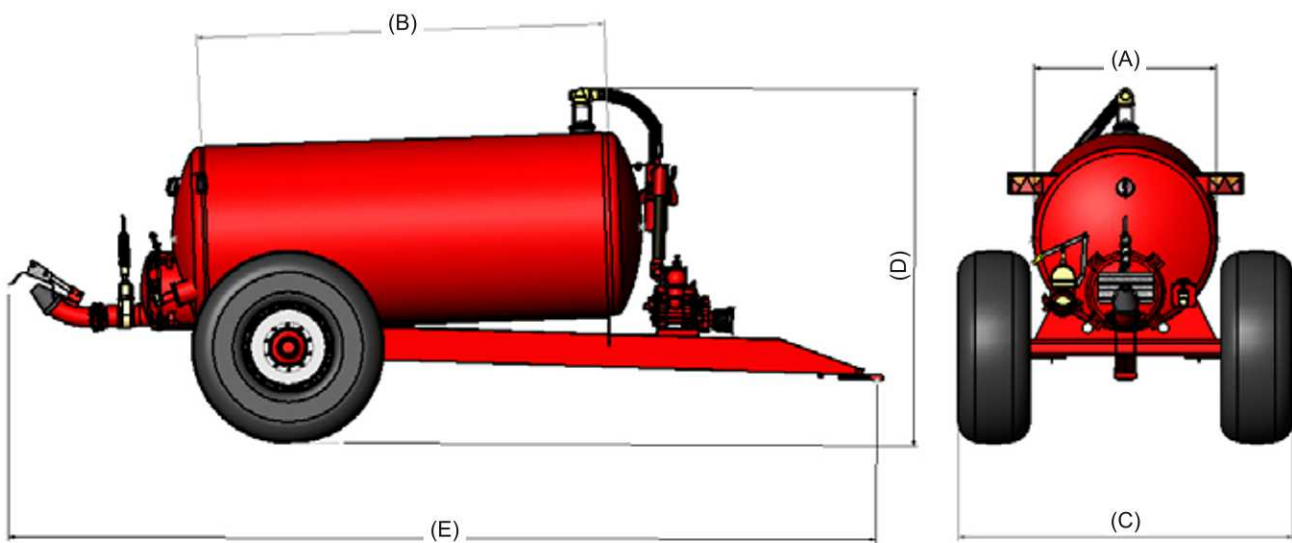

SINGLE AXLE TANKER C/W NON-RECESSED BARREL SPECIFICATION SHEET

Item	Tanker Size	A Dome Ø	B Barrel Length (m) Excluding dome	C Tanker Width (m)	D Overall Height (m)	E Overall Length exc. applicator (m)	Vacuum Pump	Axle	Brakes (Hydraulic)	Tyres
6	1600 Gallon (7260 Litre)	1.52 (60")	3.65	2.55	3.0	6.6***	9000L	90mm 8 Stud	400 x 80	550/60 x 22.5
7		1.52 (60")	3.65	2.56	3.0	6.6***	9000L	90mm 8 Stud	400 x 80	560/60 x 22.5
8		1.52 (60")	3.65	2.54	3.1	6.6***	9000L	90mm 8 Stud	400 x 80	21.3 x 24
9		1.52 (60")	3.65	2.65	3.1	6.6***	9000L	90mm 8 Stud	400 x 80	600/55 x 26.5
10	1850 Gallon (8400 Litre)	1.68 (66")	3.65	2.56	3.2	6.6***	9000L	90mm 8 Stud	400 x 80	560/60 x 22.5
11		1.68 (66")	3.65	2.65	3.3	6.6***	9000L	90mm 8 Stud	400 x 80	600/55 x 26.5
12		1.68 (66")	3.65	2.7	3.3	6.6***	9000L	90mm 8 Stud	400 x 80	650/55 x 26.5
13	2050 Gallon (9300 litre)	1.68 (66")	4	2.56	3.2	6.8***	11000L	90mm 8 Stud	400 x 80	560/60 x 22.5
14		1.68 (66")	4	2.65	3.3	6.8***	11000L	90mm 8 Stud	400 x 80	600/55 x 26.5
15		1.68 (66")	4	2.81	3.3	6.8***	11000L	90mm 8 Stud	400 x 80	710/50 x 26.5

Dimensions are for standard vacuum tankers and subject to change depending on options selected. In accordance with our policy of continued development we reserve the right to alter specification dimensions and/or design without notice.

*** Overall length is measured to the rear valve and excludes a splash plate applicator or any other optional extras.